



Van's RV & Lancair Cowling Kit Installation Instructions

WARRANTY: MilSpec will replace any part that is found to be defective in material or workmanship upon return and inspection for up to one year after the invoice date. This warranty does not cover damage to any other components, labor, personal injury or any other damage or injury. This warranty is expressly in lieu of any other warranty expressed or implied and / or any other liability or obligation on the part of MilSpec. **Quarter turn fasteners are not designed for excessive torque.** If excessive torque is required to lock the stud, there is a problem with the installation. Usually the fastener is too short for the application or the receptacles are improperly installed. Forcing the fastener to lock will only weaken the stud assembly and potentially cause the entire system to fail. **MilSpec does not warranty fasteners with obvious signs of excessive torque. Proper stud installation should allow the fastener to be operated by a screw driver held only with the thumb and two fingers.**

WARNING: All components contained in this kit are approved for aircraft use under TSO-C-148. Buyer takes full responsibility for the proper use and installation of the parts contained herein by qualified personnel and that the appropriate log book entries are made and that this installation is in accordance with all relevant FAA regulations.

EXCHANGES OR ADDITIONAL ITEMS: MilSpec will gladly exchange parts which are returned in new condition only. Items which are scratched or indicate use will not be accepted. This kit is priced on a per item basis. If your application requires additional items, these items will be charged additionally. Any extra parts may be returned for credit within 30 days of purchase provided that they are in new condition and suitable for resale (\$5.00 minimum total). Prior authorization for returns must be obtained from MilSpec so that we may keep track of all lot numbers as per FAA regulations. COD returns will not be accepted.

INSTALLATION PARAMETERS: Each builder will have their own preference but, this kit assumes 3.5" to 4.25" spacing between fasteners. The distance from the edge of the cowling to the center of the fastener hole should be a minimum of 5/8". The total width of the support strip should be 2.5". The overlap amount (receptacle mounting lip) should be a minimum of 1-1/8" preferably 1-1/2" and the thickness of this strip should be a minimum of .040". Due to the limited space and contour of the cowling nose area just behind the spinner, we can not use 1/4 turn fasteners in this area. We suggest plate nuts and machine screws here.

This kit is designed around the Vans RV series of aircraft and can be generally applied to many other kit plane designs. The fastener count in this kit is intended to provide 3.5" to 4.25" spacing between fasteners. This spacing is adequate to carry the load of internal air pressure when in flight for most aircraft cowlings subjected to VNE of 250 or less without adding additional re-enforcement structure. However, please keep in mind that wider spacing can be used if the cowling is re-enforced with some kind of doubler structure adjacent to the fastener line. Most commercial aircraft cowlings have some kind of support structure at the fastener locations. Take a look at any Cessna, Beech or Piper cowling to see the various ways of accomplishing the re-enforcement. Newer generation Sam James cowlings still assume the builder will be using the hinge / pin system but they have also added built in re-enforcement along the fastener lines to accommodate 1/4 turn fasteners and work well with this kit right out of the box. The first RV cowlings did not have this structure because the hinge / pin system provided the rigidity required. However as time passed and more builders preferred a 1/4 turn fastening system it became necessary to add re-enforcement along the cowling edge to prevent the cowling from bulging between fasteners in flight. Typically the builder would use a simple fiberglass lay up adjacent to the fastener line as close to the edge as possible without adding to the cowling overlap thickness to accomplish the re-enforcement. If you have an older generation cowling or want to add re-enforcement structure try our MilSpec MS2D doubler material.

KIT COMPONENTS: This kit utilizes MilSpec's 4000 series fastener system in stainless steel with our adjustable receptacles. The stud assemblies are a -2 length and can be slotted head or Phillips head. The standard grommets will accommodate a cowling thickness of up to .094" and are retained by a simple snap ring. The receptacles are adjustable depth to fit a variety of panel thicknesses. They are adjustable in .015" increments for a very precise fit.



PREPARATION: Planning to use the installation parameters above, fabricate the receptacle mounting strips. We recommend using 2024-T3 aluminum that is .050" thick with a standard "Alclad" coating. Some builders have had good success with other materials (6061-T6) and thicker or thinner strips but, keep in mind the .040" minimum thickness requirement. Some builders have

also made this flange from fiberglass which is pretty neat. You can see the process here:



<http://www.vansairforce.com/community/showthread.php?t=36697>



CONSIDERATIONS: When using MilSpec fasteners down the horizontal sides of the cowling where the upper and lower cowls come together it is important to plan your fastener spacing so that the rocker box covers of your engine will not interfere with the receptacles. Plan the spacing to allow the receptacles to be between covers.

It is recommended that you strap the cowlings tightly together to make sure everything lines up properly.

Then layout and mark the intended fastener locations spaced approx. 3.5" to 4.25" apart and 5/8" from the edge of the cowling on the exterior of the cowling skin. Drill the center pilot holes through the cowling skin and support strips. Place a cleko in each hole as you proceed to drill each location around the cowling. Once all the fastener center pilot holes are drilled the next step is to prep the support strips and mount the receptacles.



We have included two drilling templates in this kit to assist in drilling the receptacle holes. First you want to use the DT-4 (small holes) to lay out the rivet holes for the receptacle. Using the center pilot hole already drilled, simply cleko the template in place. Be sure the template is straight and aligned properly considering the cowling edge. Next, drill one of the rivet holes and cleko it in place and then drill the final rivet hole. Proceed around the mounting strips and repeat this process at each location.

Once you have drilled all the rivet holes and center pilot holes you can cleko the drill template DT-4B (large center hole) in place from the back side and enlarge the center hole to the limit of the template (1 1/16") using a UniBit (step drill). Some builders have done the install with holes as small as 1/2" which will allow proper clearance for the grommet and retainer but, we recommend the bigger hole to allow for minor misalignment. Finally, countersink the rivet holes.

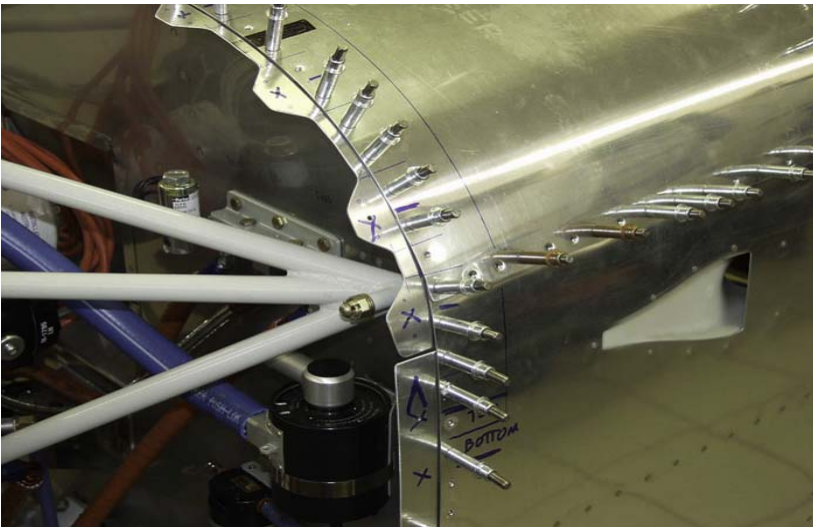

Also note that you will want to do some scalloping of the mounting strip between the receptacles that go around the top of the firewall. This is so the tabs can be slightly bent up or down to fit the contour of the cowl and fuselage.

Alternatively, you could make individual tabs for attachment at each fastener location. Some builders prefer this method to avoid making one long scalloped piece.

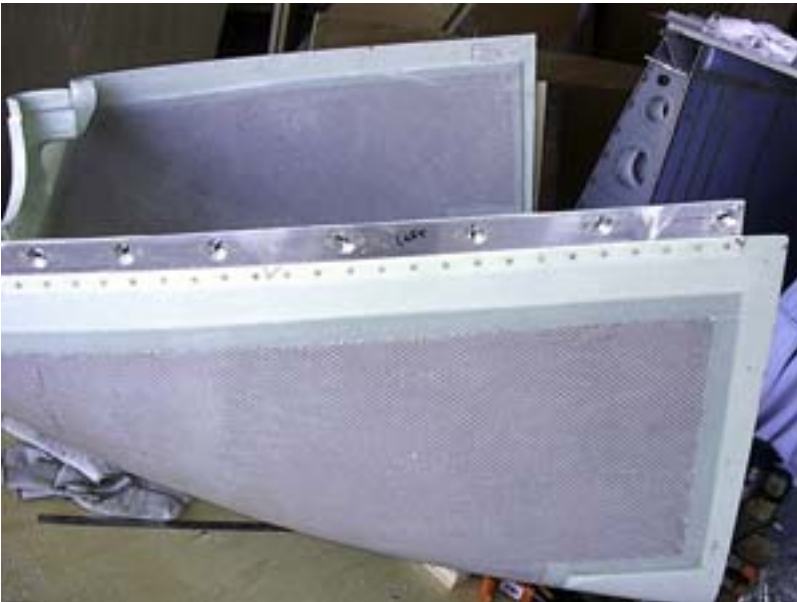

The support strips along the sides need at least 1-1/8" (preferably 1-1/2") width from the lower cowl edge (step) to the upper edge of the strip. This same dimension is required for the firewall support strips.

This is a picture of the cowling support strips mounted and drilled with the receptacles installed for the horizontal sides of the cowling. This builder used .062" thickness strips, simply riveted it to the cowl along the edges and followed our standard instructions. It came out beautifully.

Some words of wisdom here from previous installs. If possible, please wait for final riveting of the lower side and bottom cowling receptacle mounting strips into place until you have riveted all receptacles on to the mounting strip(s). Riveting them to the plane can be time consuming and a bit more difficult.

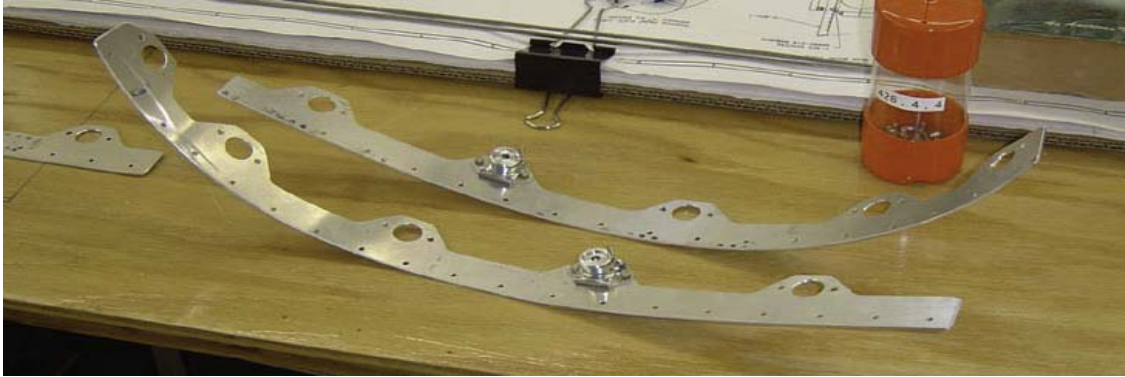

INSTALLING FASTENERS AND GROMMETS: Next, the center pilot holes in the cowling can be enlarged to accommodate the fastener grommets (15/32"). Use a UniBit (step drill) for this to make sure you get nice round holes. With the holes enlarged the grommets can be installed and the grommet retaining rings can be put on the back side (inside) of the cowling to retain them. We recommend using tool number MS-T26 for this job. It can be done without the tool but will be frustrating and take much more time. Once the grommets are installed the stud assemblies are inserted through them using 4P3 pliers (required). Similar to cleko pliers, they depress the stud assembly so that it can be angled through the grommet. Now everything should be installed and the receptacle mounting strips attached.

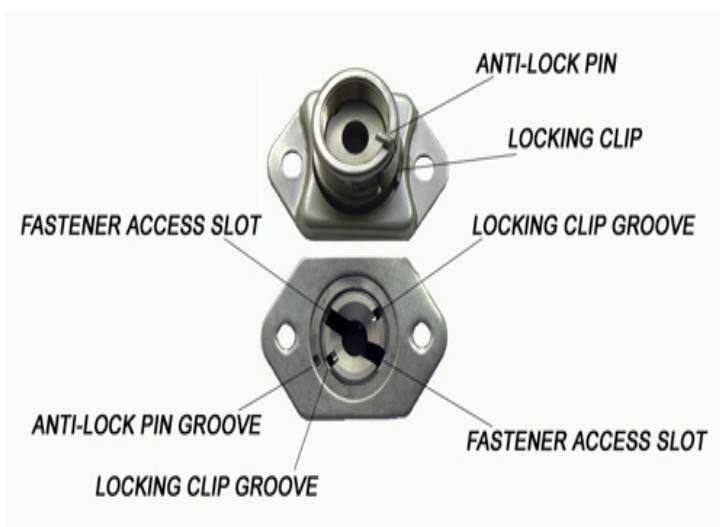
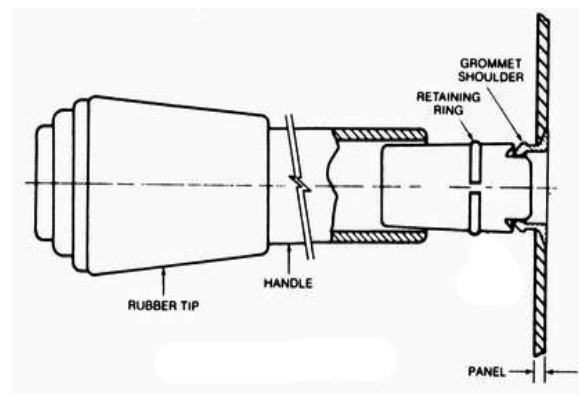
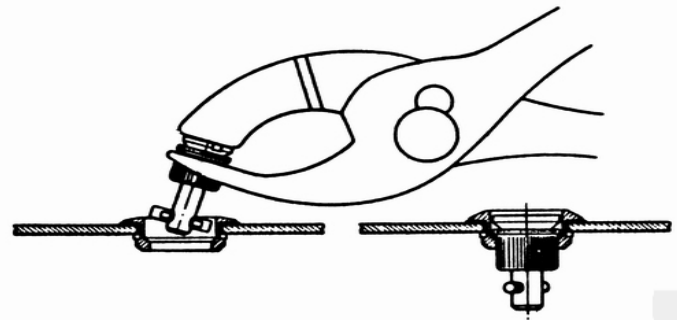

DEPTH ADJUSTMENT OF RECEPTACLES: The next step is to mount the cowling, engage the fasteners and adjust the receptacles for proper depth. But before we do that, let's take some time to get familiar with the features and components that make up the receptacle assembly.

ADJUSTABLE RECEPTACLES: The main components are a threaded barrel, threaded insert, locking clip and anti-lock pin. The insert is the portion that the fastener stud

locks into. It has two straight vertical grooves machined on the outside diameter. These grooves are where the locking clip engages to prevent the insert from rotating after the proper depth has been acquired. For the initial adjustment we have installed an anti-lock pin in a groove on the O.D. of the barrel, underneath the locking clip. This pin keeps the locking clip from engaging until the proper fit is determined. **These pins should be left in for the installation and panel fitting process but, they MUST be removed prior to flight.** If the pins are not removed and the inserts are not properly locked, the fasteners could potentially unlock in flight. Be sure that the locking clip is properly engaged into one of the locking grooves of the receptacle insert (not the fastener access slots) and that the insert does not rotate more than 5° in either direction using reasonable force.

INSTALLING THE COWLING: Now that the fasteners, grommets, and receptacles are installed, position the cowling and engage the fasteners into the receptacles. We find the best way to fasten the cowling is to engage the fasteners at the corners first and then fasten the rest working from the center out. This helps to align everything and avoid any binding situations. The studs should lock with the head protruding slightly from the grommet, this is normal. If you are having trouble engaging or locking a stud, remove the stud from the cowling with the 4P3 pliers and check for center alignment of the fastener and receptacle. Although the receptacles in this kit are floating and should accommodate minor misalignment, they are limited to 1/16" total float. Anything beyond this may require adjustment of the receptacle mounting position. Lock all of the studs that do not appear to have an alignment problem. If any receptacles require center alignment, make note of which direction they need to be moved and plan to make the necessary adjustments.

INITIAL RECEPTACLE ADJUSTMENT: The studs should be locked with the head protruding slightly from the grommet which is normal. To perform the initial depth adjustment of the receptacles, simply turn the studs clockwise just like tightening a screw until the stud head is just flush with the grommet. Proceed around the cowling performing this operation at all locations. **Do not go beyond flush as this will over stress the stud assembly.**

Now that all locations have been fitted and any receptacles requiring final alignment adjustments have been noted, the cowlings can be taken back off and the anti-lock pins are removed from the receptacles. **To unlock the studs without spinning the receptacle insert, you will need some fancy wrist action and a bit of a feel for it. The way to do this is to push in on the stud head slightly and with a quick motion, release pressure while giving the stud a 1/4 turn counter clockwise.** This is not difficult but, may take a few attempts to get it just right.

LOCKING THE INSERT AND SETTING RECEPTACLE DEPTH: Once the studs are unlocked and the cowling is removed, go to the receptacle and remove the anti-lock pin. Before removing the pin make sure the locking clip is lined up with one of the locking grooves in the insert. Note that there are two locking grooves in the insert 180° apart. This allows adjustments in .015" increments. Typical studs vary in length by .030" so with the MilSpec Adjustable receptacles you can fine tune the fit of your cowling in increments equal to ½ of a typical stud length. You may need to turn the insert with a flat blade screwdriver a half turn or so until one of the grooves in the insert comes around to the position of the locking clip. **Be sure that the locking clip is engaged into the locking groove of the insert and not the fastener access slots.** When the clip locks into the insert groove you should hear a positive snap. Verify that the entire pin is completely removed and that the insert will not rotate more than 5° in either direction using reasonable force. Proceed around the cowling and repeat this process at all locations. In some instances it may be necessary to press on the O.D. of the receptacle locking clip to help it fully engage.

RE-ADJUSTMENT: This design may be adjusted as often as required. In the event that re-adjustment of the receptacle depth becomes necessary in the future the MS-PK pick tool or any thin pick tool can be inserted into the anti lock pin groove of the receptacle. Properly engaged, this will lift the locking clip away from the insert enough to allow a flat blade screwdriver to turn the insert in the appropriate direction. Note that there are two locking grooves in the insert 180° apart. This allows adjustments in .015" increments. Typical studs vary in length by .030" so with the MilSpec Adjustable receptacles you can fine tune the fit of your cowling in increments equal to ½ of a typical stud length.

After the receptacle has been properly re-adjusted, be sure to re-engage the locking clip into one of the locking grooves in the insert. Be sure the clip is engaged in one of the locking grooves not the fastener access slots and that the insert will not rotate more than 5° in either direction using reasonable force. In some instances it may be necessary to press on the O.D. of the receptacle locking clip to help it fully engage.

